

KM130

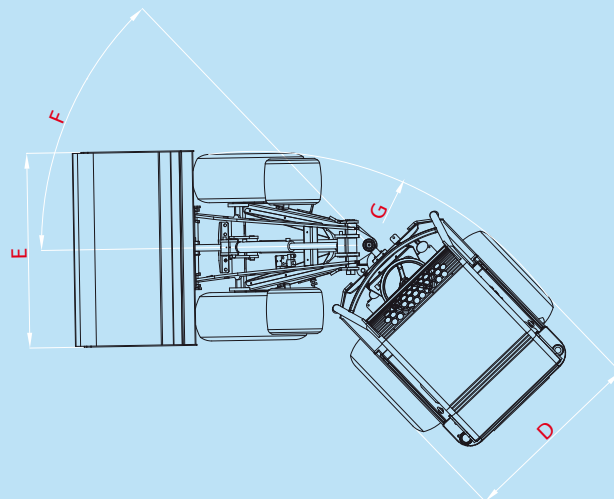
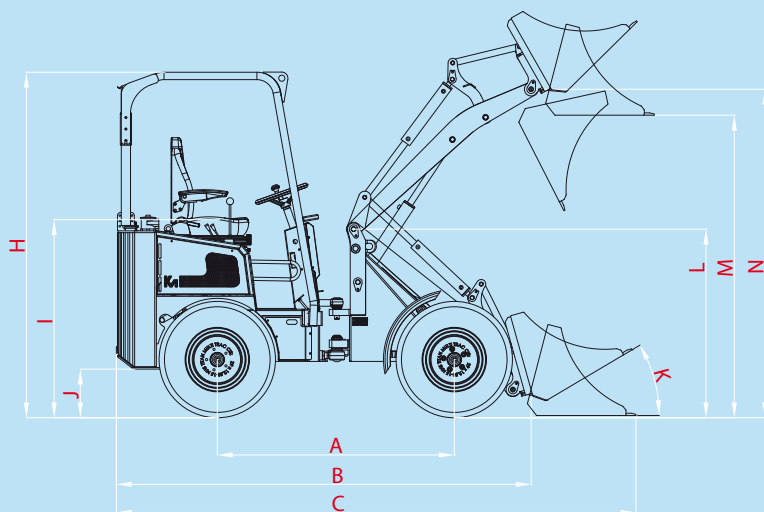

			KM130	KM130H	KM130TE
A	[mm]	wielbasis	1550	1585	1650
B	[mm]	totale lengte zonder bak	2710	2710	2860
C	[mm]	totale lengte met bak	3390	3390	3540
D	[mm]	totale breedte	950/1250	950/1250	950/1250
E	[mm]	breedte bak	1000/1270	1000/1270	1000/1270
F	[°]	maximale draaihoek	47	47	47
G	[mm]	draaicirkel buitenkant	2400	2400	2400
H	[mm]	hoogte rollbeugel / hoogte ROPS-FOPS	2170/2260	2170/2260	2170/2260
I	[mm]	zithoogte	1270	1270	1270
J	[mm]	bodemvrijheid	315	315	315
K	[°]	inkiephoek vanaf grondvlak	30	30	30
L	[mm]	hoogte giekscharnier	1230	1465	1320
M	[mm]	overlaadhoogte	1975	2570	2420/3030*
N	[mm]	max. hoogte scharnier aanpik	2145	2740	2590/3200*
	[L]	inhoud brandstoftank	37	37	37
		type dieselmotor (kubota)	V1505	V1505	V1505
	[kw/pk]	motorvermogen	26/36	26/36	26/36
		aantal cilinders	4	4	4
		aandrijfhydrauliek	plunjerpomp	plunjerpomp	plunjerpomp
		wielaandrijving	plunjermotor	plunjermotor	plunjermotor
	[L/min]	debiet werkhydrauliek	42	42	42
	[bar]	werkdruk hydrauliek	180	180	180
	[kg]	rijklaar gewicht zonder hulpstuk	1350	1500	1700
	[kg]	hefkracht	900	850	875
	[kg]	uitbreekkracht	1000	950	975
	[km/h]	rij snelheid	20	20	20

Telescooparm ingeschoven/Telescooparm uitgeschoven*

	1	2	3	4	5	6	7
KM130 niet geknikt	1160	1000	850	680	1460	1200	900
met contra gewicht 100 kg	1158	1158	1030	790	1463	1180	1044
KM130 30° geknikt	980	740	580	440	1120	830	590
met contra gewicht 100 kg	1071	962	760	573	1195	920	790
KM130TE niet geknikt	1160	1010	850	680	1460	1200	900
KM130TE 30° geknikt	950	720	560	460	1120	710	570
KM130TE telescooparm uit	610	480	420	250	710	440	390
KM130TE uit 30° geknikt	530	400	330	250	610	430	320

