

KM90-100

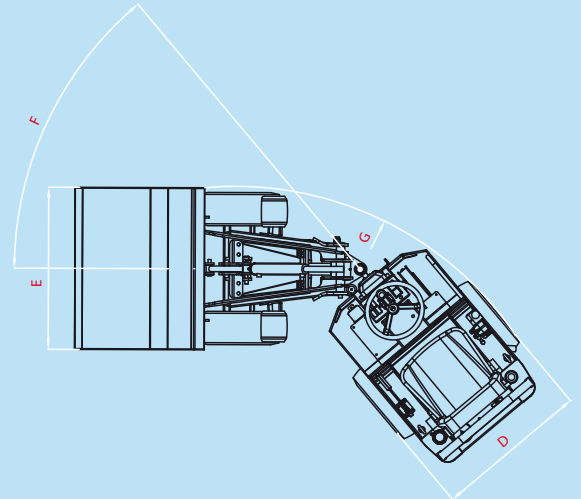
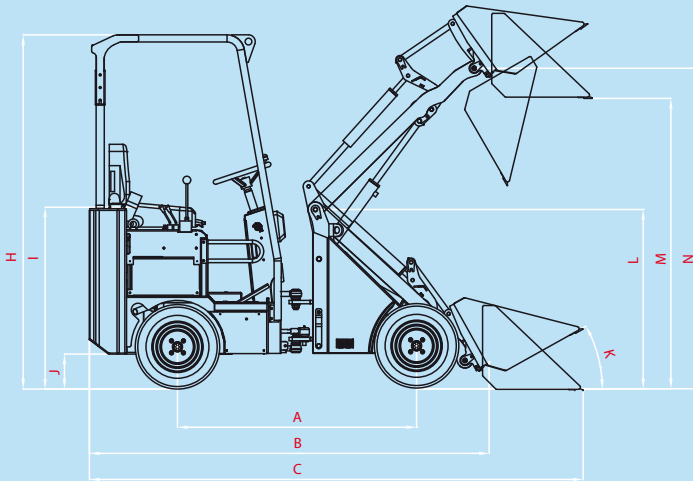

		KM90	KM100	KM100TE	
A	[mm]	wielbasis	1445	1445	1530
B	[mm]	totale lengte zonder bak	2400	2400	2610
C	[mm]	totale lengte met bak	2940	2940	3250
D	[mm]	totale breedte	930/1180	930/1180	930/1180
E	[mm]	breedte bak	960/1250	960/1250	960/1250
F	[°]	maximale draaihoek	45	45	45
G	[mm]	draaicirkel buitenkant	2380	2380	2380
H	[mm]	hoogte rollbeugel / hoogte ROPS-FOPS	2225/2250	2225/2250	2225/2250
I	[mm]	zithoogte	1125	1125	1125
J	[mm]	bodemvrijheid	245	245	245
K	[°]	inliephoek vanaf grondvlak	32	32	30
L	[mm]	hoogte giekscharnier	1165	1165	1265
M	[mm]	overlaadhoogte	1775	1775	2230/2790*
N	[mm]	max. hoogte scharnier aanpik	2030	2030	2405/2965*
	[L]	inhoud brandstoftank	33	33	33
		type dieselmotor (kubota)	D1105	D1105	D1105
	[kw/pk]	motorvermogen	19/25	19/25	19/25
		aantal cilinders	3	3	3
		aandrijfhydrauliek	plunjerpomp	plunjerpomp	plunjerpomp
		wiel aandrijving	orbitmotor	plunjermotor	plunjermotor
	[L/min]	debiet werkhydrauliek	28	28	28
	[bar]	werkdruk hydrauliek	180	180	180
	[kg]	rijklaar gewicht zonder hulpstuk	950	1000	1280
	[kg]	hefkracht	650	700	675
	[kg]	uitbreekkracht	750	800	775
	[km/h]	rij snelheid	16	18	18

Telescooparm ingeschoven/Telescooparm uitgeschoven*

	1	2	3	4	5	6	7
KM90 niet geknikt	930	850	660	540	1020	950	680
met contra gewicht 100 kg	930	850	730	690	1020	950	710
KM90 30° geknikt	760	600	460	360	920	660	490
met contra gewicht 100 kg	930	730	530	430	920	800	610
KM100 niet geknikt	1005	915	855	535	1250	1000	755
met contra gewicht 100 kg	1005	915	855	705	1250	1060	920
KM100 30° geknikt	1005	900	840	505	1250	1000	740
met contra gewicht 100 kg	1005	900	855	755	1250	1050	910

